



EP50 EFFLUENT PUMP

FEATURES

- Heavy duty cast iron construction
- Oil-filled continuous duty PSC motor
- Upper and lower ball bearing construction
- Cast iron vortex impeller, 3/4" solids handling

*Honest
Professional
Dependable*

1899 Cottage Street, Ashland, Ohio 44805

Telephone: 855 281-6830 · Fax: 877 326-1994

ashlandpump.com



EP50 - 1/2 HP Effluent Pump

TECHNICAL DATA

Physical Data:

DISCHARGE SIZE **2" NPT**
 IMPELLER TYPE **2-Vane Closed - Cast Iron**
 CABLE LENGTH **20'**

Liquid Handling:

SOLIDS SIZE **3/4"**
 MAXIMUM LIQUID TEMP. **104°F - Intermittent**
 ACCEPTABLE PH RANGE **6-8**

Temperature:

MAXIMUM STATOR **120°C**
 OIL FLASH POINT **140°C**

Technical Data:

POWER CORD TYPE **SOW 16/3C**
 MOTOR HOUSING **Cast Iron**
 CASING **N/A**
 IMPELLER **Cast Iron**
 MOTOR SHAFT **SS430**
 HARDWARE **SUS**
 "O" RINGS **NBR**
 MECHANICAL SEALS **Standard**
 UPPER BEARING **6203**
 LOWER BEARING **6203**

ELECTRICAL DATA

R.P.M. **3450**
 MOTOR TYPE **PSC**
 GEN INSULATION CLASS **B**
 STATOR WINDING CLASS **B**
 MAXIMUM STATOR TEMP **120°C**
 VOLTAGE TOLERANCE **±10%**
 MOTOR PROTECTION **Thermally Protected**
 HP **1/2**
 VOLTAGE **115/230**
 PHASE **1**
 SERVICE FACTOR **1**
 FULL LOAD AMPS **12.0/6.0**

DIMENSIONAL DATA

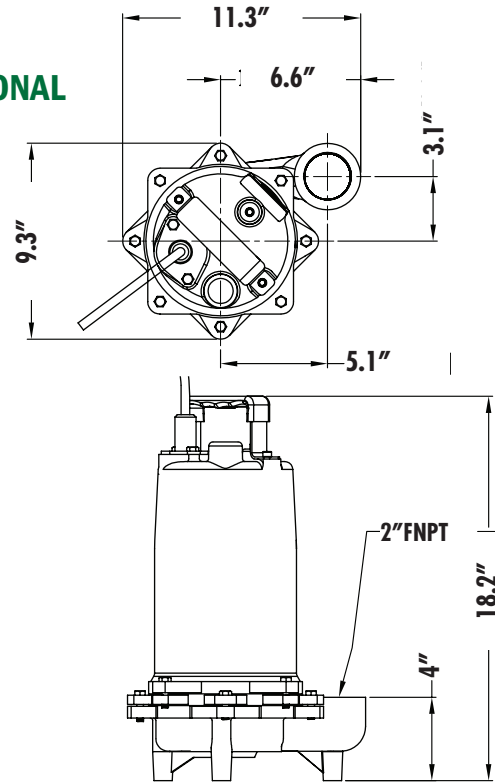

PERFORMANCE CURVE

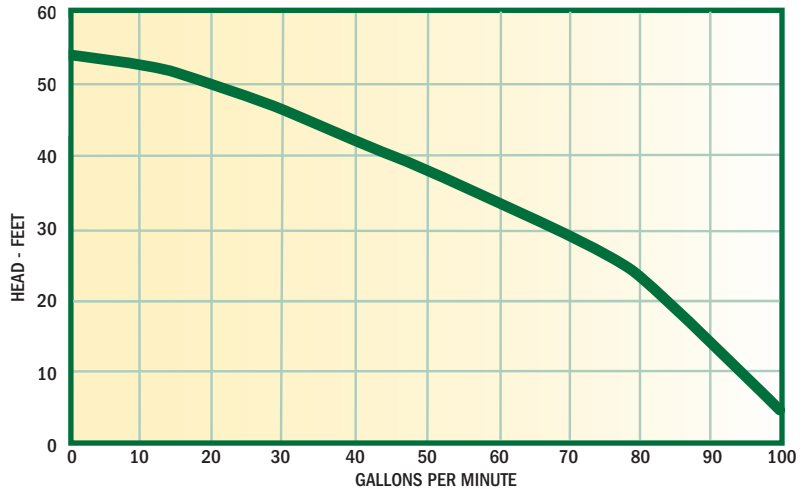

PERFORMANCE CHART

Total Lift(feet)	0	10	20	30	40	50	53
GPM	102	95	85	68	45	20	0



P U M P

Honest, Professional, Dependable

1899 Cottage Street, Ashland, Ohio 44805
 Telephone: 855 281-6830 · Fax: 877 326-1994 · ashlandpump.com