



SWH50 SEWAGE PUMP

FEATURES

- Heavy duty cast iron
- Oil-filled continuous duty PSC motor
- Vortex impeller
- 2" NPT Flanged Discharge, 3" NPT Optional

***Honest
Professional
Dependable***

1899 Cottage Street, Ashland, Ohio 44805

Telephone: 855 281-6830 · Fax: 877 326-1994

ashlandpump.com



SWH50 - 1/2 HP Submersible Sewage Pump

TECHNICAL DATA

Physical Data:

DISCHARGE SIZE **2" NPT Flanged Discharge, 3" NPT Optional**
 IMPELLER TYPE **Vortex - Cast Iron**
 CABLE LENGTH **20'**

Liquid Handling:

SOLIDS SIZE **2"**
 MAXIMUM LIQUID TEMP. **104°F - Intermittent**
 ACCEPTABLE PH RANGE **6-8**

Temperature:

WINDING INSULATION TEMPERATURE **130°C**

Technical Data:

POWER CORD TYPE **SOW 16AWG/3C, 16AWG/4C**
 MOTOR HOUSING **Cast Iron**
 CASING **Cast Iron**
 IMPELLER **Cast Iron**
 MOTOR SHAFT **SS430**
 HARDWARE **SST**
 "O" RINGS **NBR**
 SEALS **Single Mechanical, Carbon Ceramic**
 UPPER BEARING **6203**
 LOWER BEARING **6203**

ELECTRICAL DATA

R.P.M. **3450**
 MOTOR TYPE **PSC/Induction**
 GENERAL INSULATION CLASS **B**
 STATOR WINDING CLASS **B**
 MAXIMUM STATOR TEMPERATURE **130°C**
 VOLTAGE TOLERANCE **±10%**
 MOTOR PROTECTION **Thermally Protected**
 HP **1/2**
 VOLTAGE **115/230/460/208**
 PHASE **1/3**
 SERVICE FACTOR **1**
 FULL LOAD AMPS **115V/1PH/12.0
 230V/1PH/6.0
 230V/3PH/4
 460V/3PH/2
 208V/1PH/6.8
 208V/3PH/4.2**

DIMENSIONAL DATA

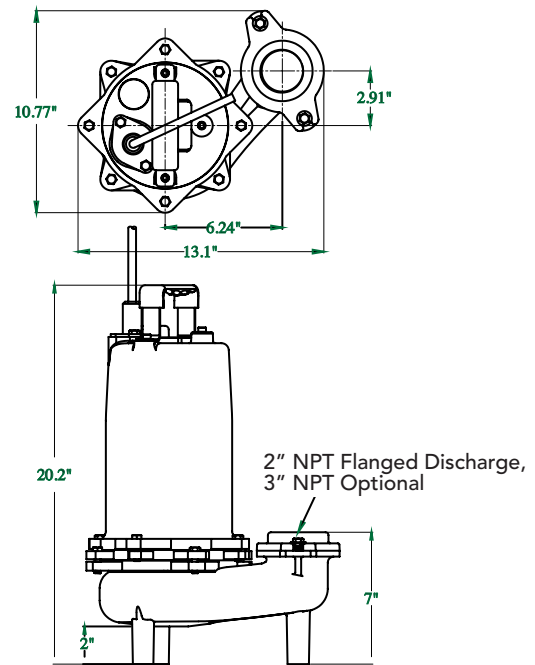

PERFORMANCE CURVE

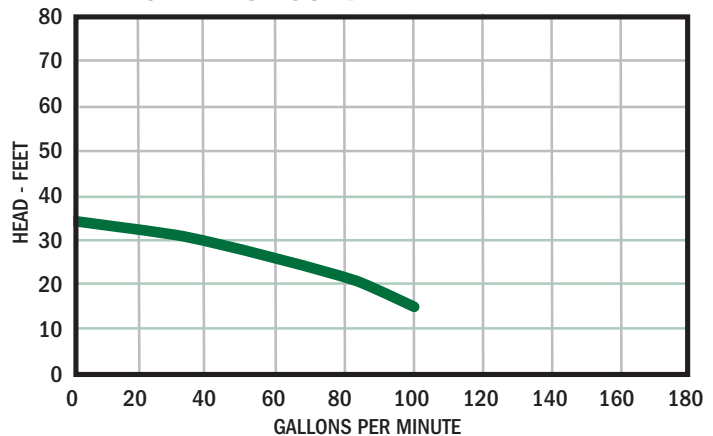

PERFORMANCE CHART

Total Lift(feet)	15	20	25	30	34
GPM	110	85	59	23	0



P U M P

Honest, Professional, Dependable

1899 Cottage Street, Ashland, Ohio 44805
 Telephone: 855 281-6830 · Fax: 877 326-1994 · ashlandpump.com